

Installation Instruction

LED Wrap Fixture

Applicable models:
DL-WA5T

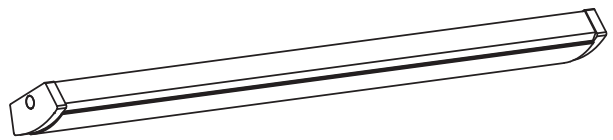

PACKAGE CONTENTS

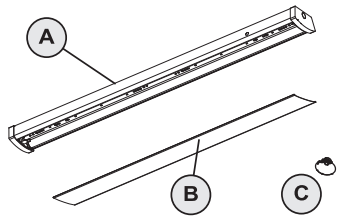

Part	Item Name	Qty.
A	Fixture	1
B	Diffuser lens (pre-installed)	1
C	Suction cup (for lens removal)	1

SAFETY INFORMATION

Please read and understand this entire manual before attempting to assemble, operate or install the product. Failure to do so could lead to electric shock, fire or other injuries that could be hazardous or even fatal.

- Be sure the electricity to the wires you are working on is shut off. Either remove the fuse or turn off the circuit breaker.
- Changes or modifications not expressly approved by the party responsible for compliance could void the user's authority to operate the equipment.

- CAUTION:**
- This product can only be dimmed with a 0-10 Volt dimming system.
 - This product must be installed in accordance with local, state and national electrical codes.
 - Installation work shall be completed by a licensed installer that is familiar with the construction and operations of the product.

SAFETY INFORMATION

NOTICE
This device complies with Part 15 of the FCC Rules. Operation is subject to the following two conditions: (1) This device may not cause harmful interference, and (2) this device must accept any interference received, including interference that may cause undesired operation.

This equipment has been tested and found to comply with the limits for a Class B digital device, pursuant to part 15 of the FCC Rules. These limits are designed to provide reasonable protection against harmful interference in a residential installation. This equipment generates, uses and can radiate radio frequency energy and, if not installed and used in accordance with the instructions, may cause harmful interference to radio or television reception, which can be determined by turning the equipment the equipment off and on. The user is encouraged to try to correct the interference by one or more of the following measures:

- Reorient or relocate the receiving antenna.
- Increase the separation between the equipment and the receiver.
- Connect the equipment into an outlet on a circuit different from that to which the receiver is connected.
- Consult the dealer or an experienced radio/TV technician for help.

INSTALLATION INSTRUCTIONS

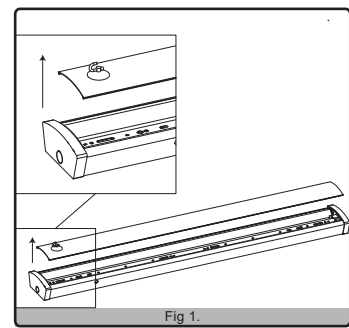

1. Remove the diffuser lens by using the supplied suction cup to lift up one end of the lens from the supporting channels. Once partially lifted up, the rest of the lens can be peeled back and completely released from the fixture body.

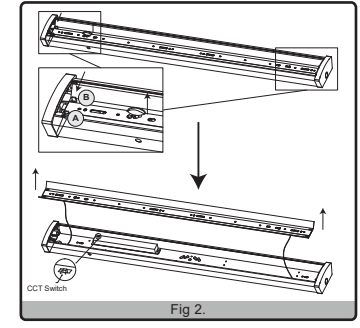

2. Use the hook on the supplied suction cup to hook and pull the reflector at the hole for the safety string and push the A-B bar at same time to take out the reflector. Configure color temperature settings, by using the slide switches on the Driver.

INSTALLATION INSTRUCTIONS

3. Using wirenuts to connect the appropriate input leads as shown in the wire diagram. Either make the connections behind the fixture and tuck wires into junction box. or pull supply leads through the fixture opening and make the connections inside the fixture housing. If connections are to be made inside the fixture housing, it may help to mount the fixture to the mounting surface first as shown in the next step. **Note:** Ensure that the wires and wirenuts are tucked away from the LED diodes to prevent casting a shadow on the diffuser lens.

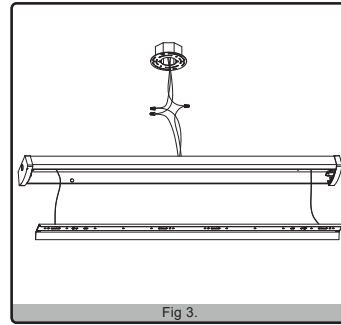

4. If wires are connected behind the fixture, carefully tuck the wires and wirenuts into the junction box before mounting the fixture. Align the fixture with the four (4) mounting screw heads so that the screw heads pass through the center part of the keyhole slots, slide the fixture to either side so that the screw heads are supporting the narrow slots of the keyhole profile.

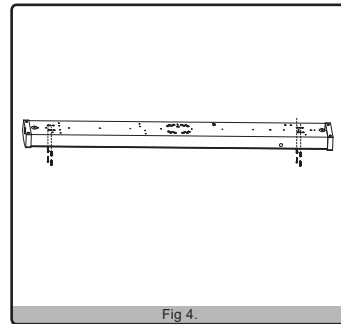

5. Re-install the reflector then apply diffuser lens by seating both sides of one end into each of the extruded channels and carefully press each side as you make your way down the length of the housing until it is fully seated.

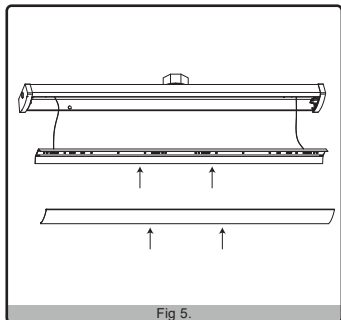

WIRING DIAGRAM

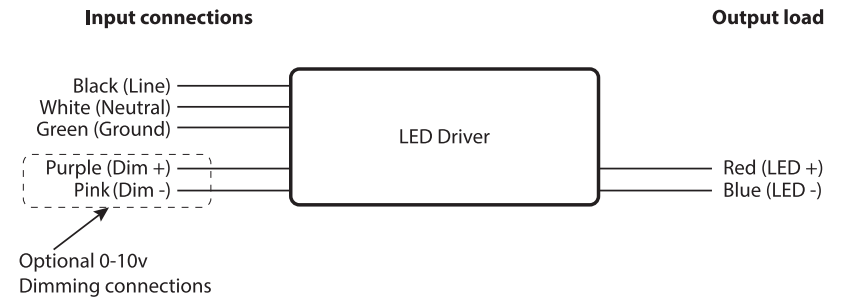

MAINTENANCE AND CARE

Clean with a mild, non-abrasive glass cleaner and soft cloth. Do NOT use solvents or cleaners containing abrasive agents. When cleaning the fixture, make sure the power is turned off, and any liquid spray should be applied to the cleaning cloth and not sprayed directly onto the fixture itself.

TROUBLESHOOTING

Problem	Possible Solution	Corrective Action
Fixture does not light.	<ol style="list-style-type: none"> 1. Power is off. 2. Incorrect wire connection. 3. Defective wall switch. 	<ol style="list-style-type: none"> 1. Check circuit breaker or wall switch. 2. Check wire splices. 3. Replace switch.
Circuit breaker trips when light is turned on.	Crossed wires or power wire is grounded out.	Verify wires are correctly connected.

WARRANTY

This fixture is warranted to perform free from defects for five (5) years.